



Lift Mast Rollers

For Industrial Trucks

Foreword

Economical solutions for industrial trucks

Lift masts are subjected to high dynamic and static loads as well as shocks, vibrations and oscillations. They are also heavily exposed to environmental influences such as heat, cold, moisture, dust, aggressive ambient air and contamination. The guidance arrangements of lift masts must therefore be particularly robust and have particularly high load carrying capacity.

For use in such challenging environmental conditions, Schaeffler Group Industrial has developed special lift mast rollers. These robust bearings are the solution where the guidance arrangements of lift masts must be economical and have high load carrying capacity and operational security.

Replacement for ...

This edition replaces MAI 98, issued in April 2006.

The data represent the current level of technology and manufacture as of October 2009. They reflect not only progress in rolling bearing technology but also the experience gathered in practical use.

Any information in previous publications that does not concur with the data in this Product Information is therefore invalid.

Lift mast rollers

	Page
Product overview	
Lift mast rollers.....	4
Features	
Sealing and lubrication	5
Operating temperature.....	5
Design and safety guidelines	
Contact with flat mating track.....	5
Dynamic load.....	6
Static load	6
Loading of lift mast rollers.....	6
Fitting.....	9
Dimension tables	
Lift mast rollers.....	10

Product overview Lift mast rollers

Double row

Lip seals on both sides

HULR

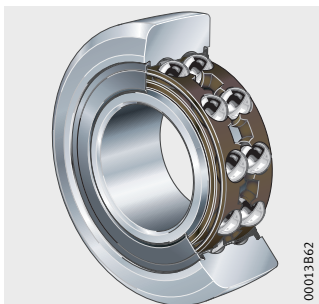

Single row

Lip seals on both sides

LRQ

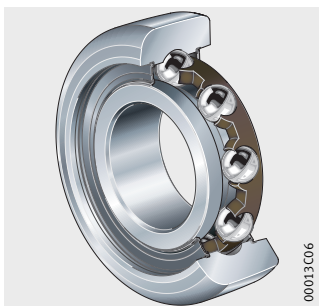

Lift mast rollers

Features

Lift mast rollers HULR are double row angular contact ball bearings without filling slots, while series LRQ is a single row four point contact bearing. The rolling elements are guided by plastic cages. The bearings can support high radial forces, axial forces and moments.

The outer rings are thick-walled solid components with a crowned outside surface. The crowned surface prevents edge loads if misalignments occur.

The inner rings are of a single-piece design. This saves on fitting costs since there is no need for axial clamping of the bearings.

Sealing and lubrication

Lip seals on both sides of the mast rollers give reliable protection of the rolling element system against contamination and moisture.

The bearings are greased for life using a high quality lithium soap grease.

Operating temperature

Lift mast rollers can be used at operating temperatures from $-20\text{ }^{\circ}\text{C}$ to $+120\text{ }^{\circ}\text{C}$.

Design and safety guidelines

The thick-walled outer rings of lift mast rollers can support high radial and shock-type loads.

Contact with flat mating track

If the rollers are in contact with a flat mating track, the outer rings undergo elastic deformation, *Figure 1*.

Compared with a rolling bearing supported in a housing bore, lift mast rollers have a modified load distribution in the bearing. This is taken into consideration in the rating life calculation using the basic load ratings C_{rw} and C_{Orw} , see dimension table.

Contact with a flat mating track leads to bending stresses in the outer ring. These are taken into consideration using the permissible radial loads $F_{r\text{ per}}$ and $F_{Or\text{ per}}$, see dimension table.



The bending stresses must not exceed the permissible strength values of the material.

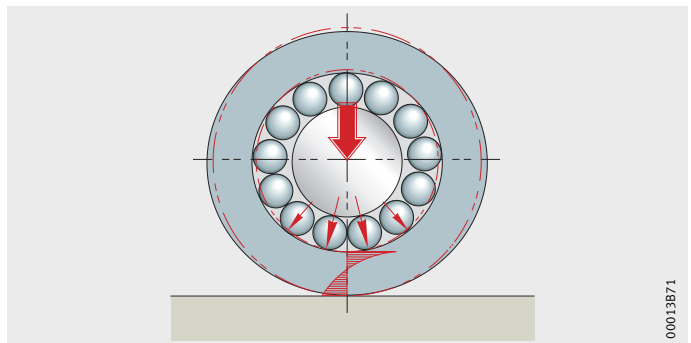

Figure 1
Deformation of the outer ring

Lift mast rollers

Dynamic load For bearings subjected to dynamic load, i. e. rotating bearings, the valid parameter is the effective dynamic load rating C_{rw} , see dimension table.



At the same time, the permissible dynamic radial load $F_{r\text{ per}}$ must not be exceeded.

Static load For bearings under static load, i. e. either stationary or with only infrequent rotary motion, the valid parameter is the effective static load rating C_{Orw} , see dimension table.



At the same time, the permissible static radial load $F_{Or\text{ per}}$ must not be exceeded.

In addition to the permissible radial load on the bearing, the permissible radial load on the mating track must also be observed, see also Catalogue HR 1, Rolling Bearings, section Track rollers.

Loading of lift mast rollers

In industrial trucks, the lift mast is used to raise and lower loads. It comprises an outer mast, inner mast and fork carrier, *Figure 2*. The carrier components in the steel construction are designed as profiled sections and are movably nested within each other in a telescopic arrangement for moving the loads.

The profiled sections are guided by lift mast rollers. The rollers transmit the forces and the moments about the transverse, longitudinal and vertical axis of the industrial truck from the fork carrier into the lift mast and from there into the frame.

Most fork lift trucks have four lift mast rollers running between the inner mast and fork carrier or four lift mast rollers running between the outer mast and inner mast.

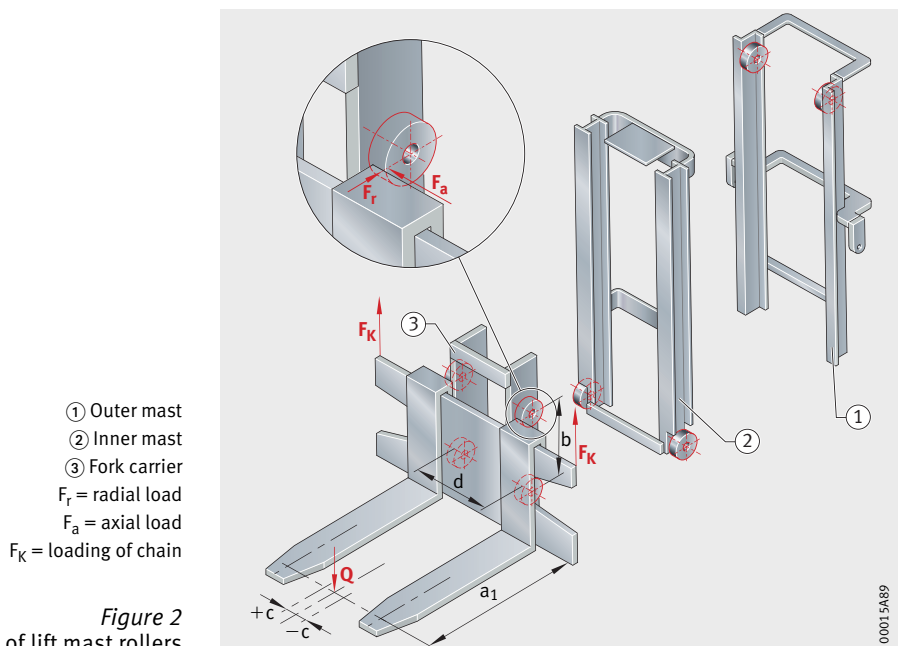

Radial load The vertical spacing between the lift mast rollers in the fork carrier as a function of the lift height remains constant. The radial load F_r on each roller thus remains constant under the same load Q and the same load centre spacing.

The radial load F_r on each lift mast roller in the fork carrier taking into account the eccentricity of load Q is shown in the following formula:

$$F_r = Q \cdot \frac{\left(\frac{d}{2} + c\right) \cdot a_1}{d \cdot b}$$

F_r N
Radial load on one lift mast roller in the fork carrier
(excluding fork carrier mass; vertical position of lift mast)

Q mm
Load on fork tines

a_1 mm
Spacing between load centre and lift chain

b mm
Vertical spacing between lift mast rollers in fork carrier

c mm
Eccentricity of load on fork tines

d mm
Horizontal spacing between lift mast rollers in fork carrier.

Axial load Axial loads occur when the load centre (viewed in the direction of travel) is off-centre. As a result, the induced moment about the longitudinal axis of the vehicle must be supported by the diagonally opposed lift mast rollers, *Figure 2*, page 6.

$$F_a = Q \cdot \frac{c}{b}$$

F_a N
Axial load on one lift mast roller in the fork carrier
(excluding fork carrier mass; vertical position of lift mast)

Q N
Load on fork tines

b mm
Vertical spacing between lift mast rollers in fork carrier

c mm
Eccentricity of load on fork tines.

Lift mast rollers

Influence of lift height on lift mast rollers

In general, the loads on the lift mast rollers in the fork carrier are greater than those on the lift mast rollers between the inner and outer mast.

It must be noted, however, that when the lift mast is fully extended, the vertical distance between the rollers in the inner and outer mast is at its minimum value e_{\min} , so the maximum forces occur in this condition, *Figure 3*.



If the fork tines are replaced by attachments such as pivots, crane arms, side loaders, paper roll grippers or scoops, extreme loads may occur on the lift mast rollers.

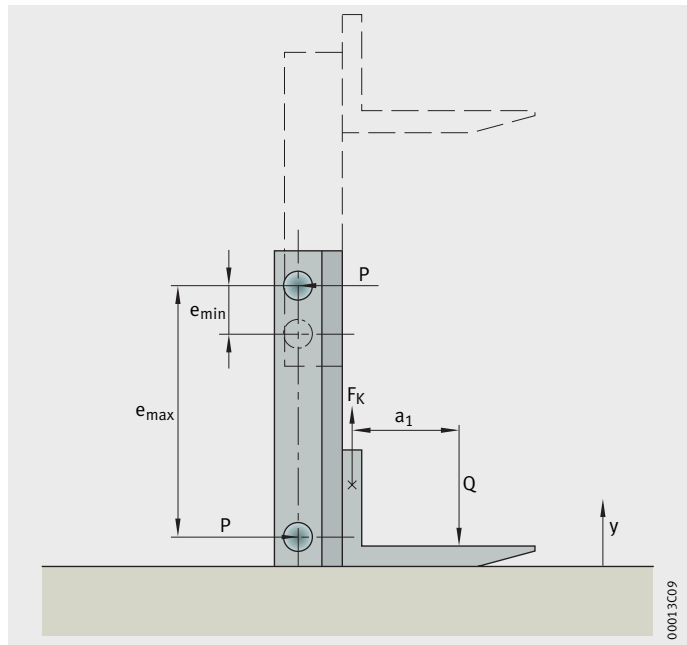
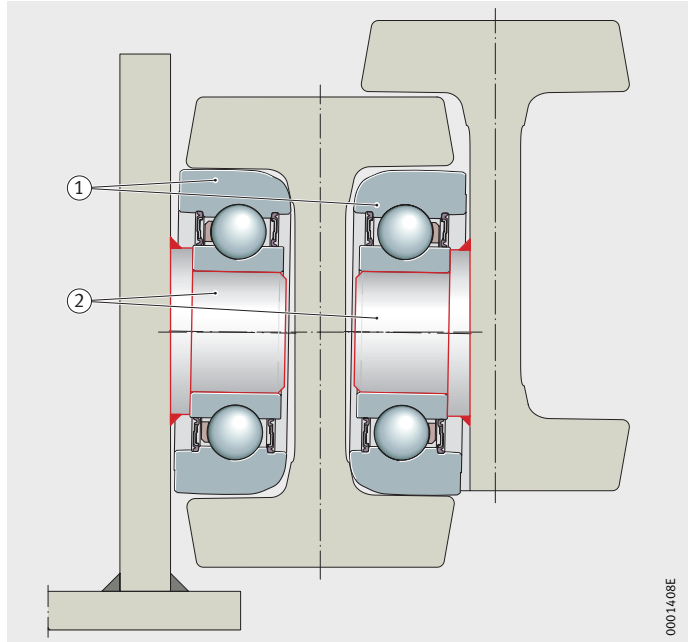

Figure 3
Influence of lift height on lift mast rollers

Fitting Lift mast rollers are mounted on studs welded at an angle to the lift mast, *Figure 4*. In this way, the forces occurring in the longitudinal and transverse direction of the vehicle are transmitted via the lift mast into the thick-walled outer ring of the bearing.



- ① Lift mast roller
- ② Stud welded at angle

Figure 4
Fitting of lift mast roller to lift mast

Clearance In order to ensure the smallest possible clearance between the lift mast roller and the profile chamber, the INA standard lift mast rollers are precisely matched to the most common standard lift mast profiles.

Clearance compensation Axial clearance is compensated by shims on the studs.

Lift mast rollers

Sealed

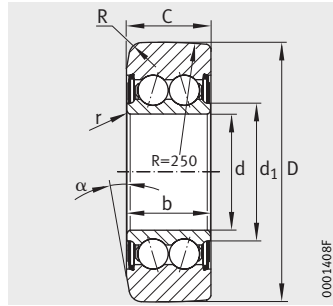

HULR

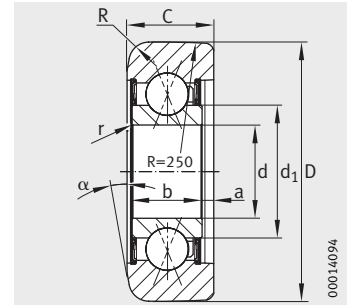

LRQ

Dimension table - Dimensions in mm

Designation ¹⁾	Drawing number	Mass m ≈kg	Dimensions								Basic load ratings			
			d	D	b	d ₁	C	r	R	α	dyn. C _{rw}	stat. C _{orw}	dyn. F _{r per}	stat. F _{or per}
									min.	°	N	N	N	N
HULR28/70.2RS	F-238741	0,45	28	70	22,6	37,7	23	0,8	6	10	18 600	14 200	18 600	28 400
HULR30/78.2RS	F-239206	0,6	30	77,9	23,6	40	24	0,8	6	10	25 000	19 100	25 000	38 200
HULR40/90.2RS	F-239207	0,85	40	88,6	28,8	52,1	29	0,8	6	10	31 500	25 000	31 500	50 000
HULR45/108.2RS	F-239208	1,53	45	107,9	33,7	60,4	34	1,6	6	10	44 500	35 000	44 500	70 000
HULR55/123.2RS	F-239209	2,26	55	123,3	39,5	65,3	40	1,5	6	10	57 000	47 500	57 000	95 000

¹⁾ Lift mast rollers are available by agreement only.

Dimension table - Dimensions in mm

Designation ¹⁾	Drawing number	Mass m ≈kg	Dimensions								Basic load ratings				
			d	D	b	d ₁	a	C	r	R	α	dyn. C _{rw}	stat. C _{orw}	dyn. F _{r per}	stat. F _{or per}
									min.	°	N	N	N	N	
LRQ 24/62.2RS	F-239210	0,36	24	62,5	20	33,5	4,1	24	0,3	6	10	20 300	14 300	20 300	28 600
LRQ 24/70.2RS	F-239212	0,5	24	70	20	33,5	4,1	24	0,3	6	10	21 500	14 800	21 500	29 600
LRQ 28/78.2RS	F-239213	0,6	28	77,9	21	39,8	3,6	26	0,3	6	10	34 500	24 200	31 500	48 400
LRQ 40/90.2RS	F-239214	0,77	40	88,6	22,4	52,8	3,5	29	1	6	10	35 500	27 000	35 500	54 000
LRQ 45/108.2RS	F-239215	1,45	45	107,9	28,5	61,5	5,6	34	1	6	10	51 000	41 000	51 000	82 000

¹⁾ Lift mast rollers are available by agreement only.

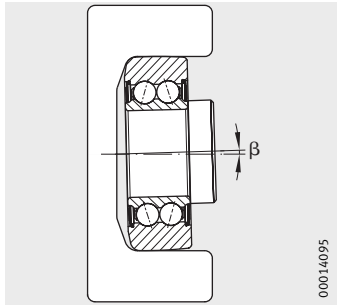

Fitting example for HULR

Hoesch profiles								Mannstaedt profiles							
U standard				I standard				U standard				I standard			
No.	Chan- nel width	Toler- ance	Adjust- ment angle β	No.	Chan- nel width	Toler- ance	Adjust- ment angle β	No.	Chan- nel width	Toler- ance	Adjust- ment angle β	No.	Chan- nel width	Toler- ance	Adjust- ment angle β
	min.	mm	°		min.	mm	°	W	min.	mm	°	W	min.	mm	°
2867	70,3	+1	1	3018	70	+1	2,5	97.034	70,3	+1	1	99.040	70	+1	2,5
2810	78,2	+1	1	3019	77,9	+1	2,5	97.035	78,2	+1	1	05.023	77,9	+1	2,5
2811	88,9	+1	1	3020	88,6	+1	2,5	97.036	88,9	+1	1	05.024	88,6	+1	2,5
2862	107,9	+1	1	3100	107,9	+1	2,5	97.037	107,9	+1	1	05.025	107,9	+1	2,5
2891	123,3	+1	1	3353	123,3	+1	2,5	97.038	123,3	+1	1	06.029	123,3	+1	2,5

Hoesch profiles								Mannstaedt profiles							
U standard				I standard				U standard				I standard			
No.	Chan- nel width	Toler- ance	Adjust- ment angle β	No.	Chan- nel width	Toler- ance	Adjust- ment angle β	No.	Chan- nel width	Toler- ance	Adjust- ment angle β	No.	Chan- nel width	Toler- ance	Adjust- ment angle β
	min.	mm	°		min.	mm	°	W	min.	mm	°	W	min.	mm	°
2890	62,5	+1	1	–	–	–	–	97.033	62,5	+1	1	–	–	–	–
2867	70,3	+1	1	3018	70	+1	2,5	97.034	70,3	+1	1	99.040	70	+1	2,5
2810	78,2	+1	1	3019	77,9	+1	2,5	97.035	78,2	+1	1	05.023	77,9	+1	2,5
2811	88,9	+1	1	3020	88,6	+1	2,5	97.036	88,9	+1	1	05.024	88,6	+1	2,5
2862	107,9	+1	1	3100	107,9	+1	2,5	97.037	107,9	+1	1	05.025	107,9	+1	2,5

Schaeffler KG

Industriestraße 1–3
91074 Herzogenaurach (Germany)
Internet www.schaeffler.com
E-Mail info@schaeffler.com

In Germany:

Phone 0180 5003872
Fax 0180 5003873

From other countries:

Phone +49 9132 82-0
Fax +49 9132 82-4950

Every care has been taken to ensure the correctness of the information contained in this publication but no liability can be accepted for any errors or omissions. We reserve the right to make technical changes.

© Schaeffler KG · 2009, October

This publication or parts thereof may not be reproduced without our permission.

TPI 166 GB-D