



Driven Linear Units

Product range

SCHAEFFLER



Driven linear units

Comprehensive product range

Transport and positioning in sophisticated feed and discharge processes places particular requirements on the components and system construction. We have developed compact, highly integrated linear actuators and linear tables to fulfil these requirements, *Figure 1*.

- ① Linear actuator with track roller guidance system and toothed belt drive
- ② Linear actuator with recirculating ball guidance system and ball screw drive
- ③ Linear table

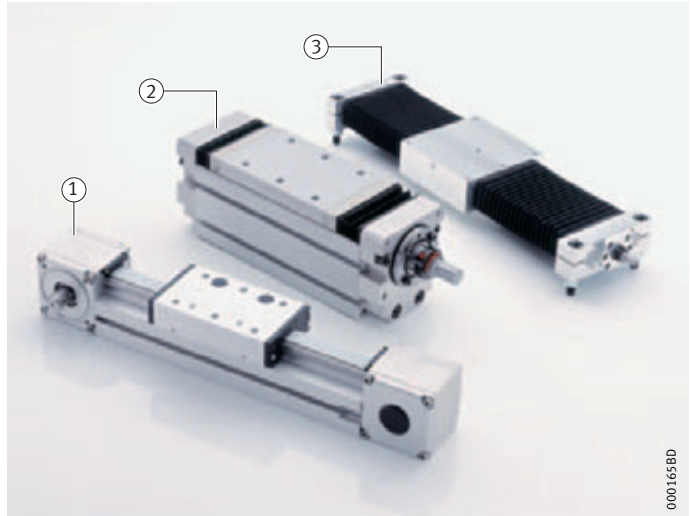

Figure 1
Linear actuators, linear table

Linear actuators

The appropriate actuator is selected as a function of the requirements for positional accuracy, positioning speed and load carrying capacity, see dimension table.

Linear actuators with additional function

For special requirements, we offer special solutions such as telescopic actuators, actuators with two opposing carriages, actuators with several carriages and non-driven linear actuators.

Linear tables

Linear tables can be used to move moderate to heavy loads in conjunction with high moment loads with high positional accuracy.

Accessories

The range is rounded out by a wide range of fasteners and retainers, couplings and gearboxes.

Drives and controls

The wide product portfolio of motors, servo controllers, sensors and components allows ready-to-fit complete solutions.

Complete solutions

Our market knowledge as a systems supplier and flexible combination of the components make it possible to achieve individual multi-axis positioning systems in close co-operation with the customer.

Driven linear units

Linear actuators

Standard linear actuators

INA linear actuators comprise an aluminium support rail with high inherent rigidity. The guidance system comprises clearance-free track roller guidance systems or recirculating ball guidance systems, *Figure 1 to Figure 3*.

The carriage is driven by one or three wear-resistant toothed belts, ball screw drive or a direct drive, see dimension table.

- ① MLFI...-3ZR
- ② MLF...-ZR
- ③ MLFI...-ZR

Figure 1
Linear actuators with track roller guidance system and toothed belt drive

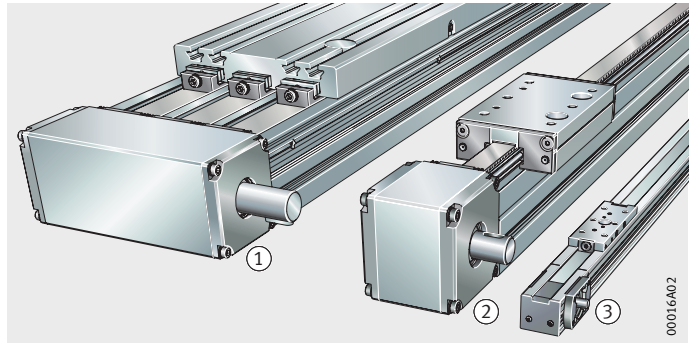

- ① MDKUV(S)E...-3ZR
- ② MKUV(S)E...-ZR

Figure 2
Linear actuators with recirculating ball guidance system and toothed belt drive

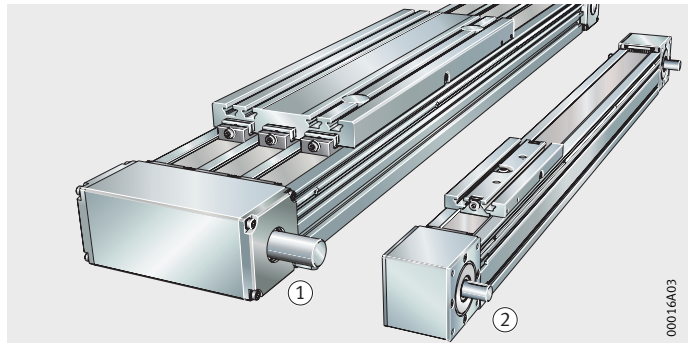

- ① MDKUV(S)E...-KGT
- ② MKUV(S)E...-KGT
- ③ MKUVS...-KGT

Figure 3
Linear actuators with recirculating ball guidance system and ball screw drive

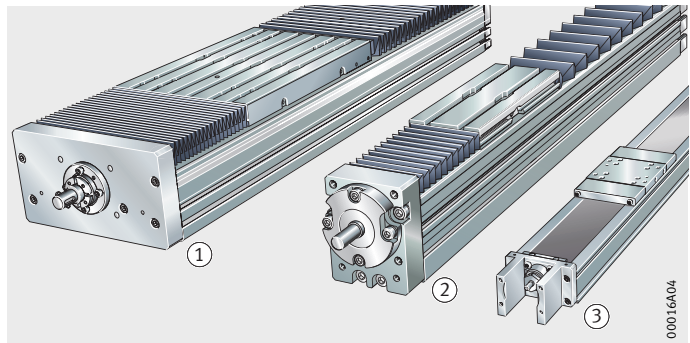

Linear actuators

Linear actuators with additional functions

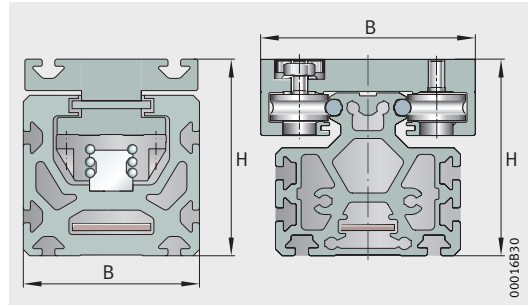

Dimension table · Dimensions in mm

Designation	Drive	Dimensions			Basic load ratings ³⁾		Positional accuracy mm	Positioning speed m/s	Publication
		B	H	Stroke length max.	dyn. C N	stat. C ₀ N			
MLFI20...-ZR	C	40	45	1 850	700	300	±0,1	4	MAI 88
MLFI25...-ZR		58	56	3 740	3 400	2 050	±0,1	4	ALE
MLFI50...-B-ZR		88	110	23 728	19 500	9 200	±0,1	8	MAI 87
MLFI140...-3ZR	C	180	105	23 706	17 500	8 000	±0,1	8	MAI 87
MLFI200...-3ZR		260	145	23 583	21 000	9 400	±0,1	8	MAI 87
MLF32...-ZR	C	86	82	23 833	4 100	2 400	±0,1	8	ALE
MLF52-130...-ZR		130	119	23 788	10 000	5 200	±0,1	8	ALE
MLF52-145...-ZR		145	125	23 743	17 800	8 900	±0,1	8	ALE
MLF52-155...-ZR		155	125	23 728	20 000	10 000	±0,1	8	ALE
MKUV20...-B-ZR	C	88	110	23 728	21 300	54 000	±0,1	5	MAI 87
MKUV25...-HS-ZR		112	125	5 475	29 000	74 000	±0,1	10	TPI 146
MKUSE25...-ZR		112	125	23 725	45 400	134 000	±0,1	5	ALE
MDKUV15...-3ZR	C	180	105	23 706	19 000	58 000	±0,1	5	ALE
MDKUSE25...-3ZR		260	145	23 583	73 900	268 000	±0,1	5	ALE
MDKUSE35...-3ZR		415	200	23 442	184 700	580 000	±0,1	5	TPI 136
MKUV15...-KGT	C	65	85	4 262	11 700	29 000	±0,025	2,5	TPI 139
MKUV20...-KGT		88	110	4 337	21 300	54 000	±0,025	2,5	TPI 139
MKUSE25...-KGT		112	125	4 126	45 400	134 000	±0,025	1,73	ALE
MKUVS32...-KGT		80	48	1 022	5 700	10 600	±0,02	1	TPI 181
MKUVS32...-80-KGT	C	80	48	972	9 300	21 200	±0,02	1	TPI 181
MDKUV25...-KGT		260	145	4 161	47 200	148 000	±0,025	1,73	MAI 94
MDKUSE25...-KGT		260	145	4 161	73 900	268 000	±0,025	1,73	MAI 94
MKLF32...-ZR ¹⁾	C	94	82	7 658	4 100	2 400	±0,1	8	MAI 87
MKLF52-130...-ZR ¹⁾		140	119	7 568	10 000	5 200	±0,1	8	MAI 87
MKLF52-145...-ZR ¹⁾		155	125	7 478	17 800	8 900	±0,1	8	MAI 87
MKLF52-155...-ZR ¹⁾		165	125	7 448	20 000	10 000	±0,1	8	MAI 87
MKKUSE20...-ZR ¹⁾		88	110	3 670	22 000	52 000	±0,1	5	MAI 87
MTKUSE25...-ZS (-ZR) ¹⁾	C	170	175	2 580	35 300	93 700	±0,5	2	ALE
MLF52-130...-ZR...-GTRI ¹⁾	C	130	119	7 788	10 000	5 200	±0,1	4,5	MAI 84
MLF52-145...-ZR...-GTRI ¹⁾		145	125	7 743	17 800	8 900	±0,1	4,5	MAI 84
MLF52-155...-ZR...-GTRI ¹⁾		155	125	7 728	20 000	10 000	±0,1	4,5	MAI 84
MKUSE25...-ZR...-GTRI ¹⁾		112	125	7 725	45 400	134 000	±0,1	4,16	MAI 84
MKUVS42...-LM ²⁾	C	140	125	23 466	27 400	51 000	±0,1	4,5	MAI 105

1) Linear actuator with additional function.



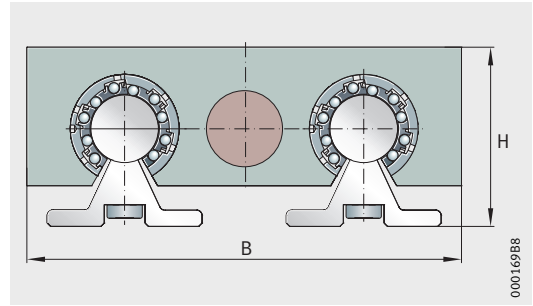

2) Linear actuator with direct drive.

3) Basic load ratings of carriage guidance system in compressive direction.

Linear tables



Dimension table - Dimensions in mm

Designation	Drive	Dimensions			Basic load ratings ⁴⁾		Positional accuracy mm	Positioning speed m/s	Publication	
		B	H	Stroke length ⁶⁾ max.	dyn. C N	stat. C ₀ N				
LTE¹⁾	-	from	65	24	911	630	860	-	5	ALE
		to	280	100	2 210	22 950	25 200	-	5	ALE
LTE..-TR²⁾		from	100	38	1 258	1 870	2 120	±0,25	0,075	ALE
		to	280	100	2 201	22 950	25 200	±0,25	0,25	ALE
LTE..-M(MM)³⁾		from	100	38	1 258	1 870	2 120	±0,005	0,25	ALE
		to	280	100	2 201	22 950	25 000	±0,025	2,5	ALE
LTS¹⁾	-	from	85	40	⁵⁾	1 580	1 780	-	5	ALE
		to	280	115	⁵⁾	23 480	26 400	-	5	ALE
LTS..-TR²⁾		from	100	48	2 648	2 110	2 480	±0,25	0,075	ALE
		to	280	115	2 858	23 480	26 400	±0,25	0,15	ALE
LTS..-M(MM)³⁾		from	100	48	1 258	2 110	2 480	±0,005	0,25	ALE
		to	280	115	4 821	23 480	26 400	±0,025	2,5	ALE
LTP..F(FM)³⁾		from	185	75	3 110	17 100	36 800	±0,005	0,25	ALE
		to	325	100	3 255	42 700	83 600	±0,02	2,5	ALE

1) Without drive.

2) With trapezoidal lead screw drive.

3) With ball screw drive.

4) Maximum basic load ratings of carriage guidance system in compressive direction.

5) Unlimited.

6) Maximum stroke without bellows cover.

Driven linear units

Linear tables

INA linear tables are used for short stroke lengths. The guidance system comprises linear ball bearings or recirculating ball guidance systems. The carriage supports moderate to heavy loads and is driven by a ball screw drive or trapezoidal lead screw drive. The linear tables are also available without drive, *Figure 1* to *Figure 4*.

Performance data:

- Acceleration up to 50 m/s^2
- Speed up to $2,5 \text{ m/s}$
- Single-piece profile length up to $1,5 \text{ m}$.

LTE,
without drive
LTE-KGT,
driven by ball screw drive
LTE-TR,
driven by trapezoidal lead screw drive

Figure 1
Linear table,
with closed linear ball bearing
guidance system

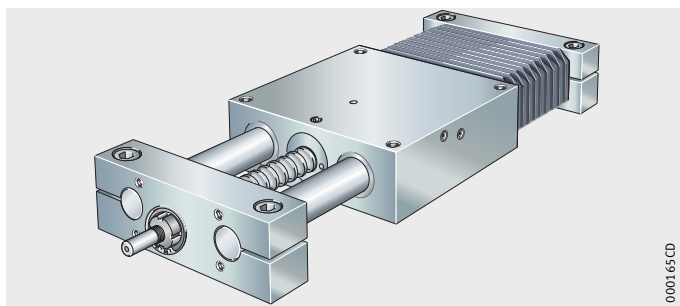

000165CD

LTS,
without drive
LTS-KGT,
driven by ball screw drive
LTS-TR,
driven by trapezoidal lead screw drive

Figure 2
Linear table,
with open linear ball bearing
guidance system

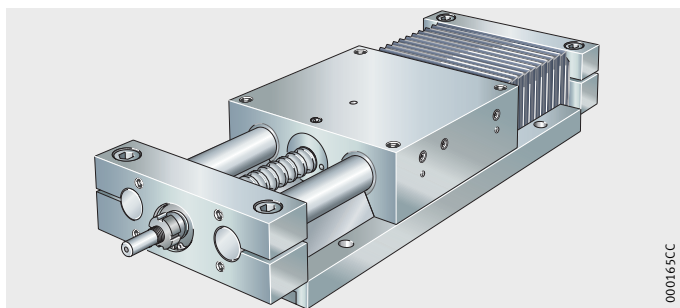

000165CC

LTP(G),
driven by ball screw drive

Figure 3
High precision linear table,
with recirculating ball
guidance system
and ball screw drive

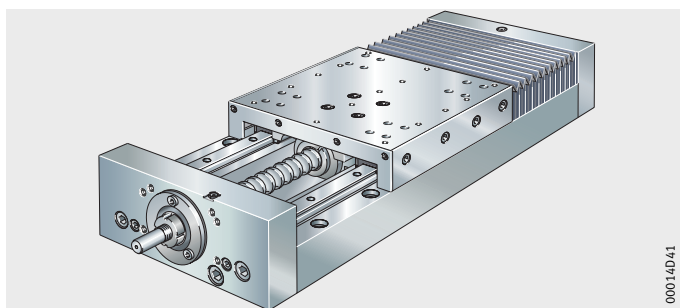

00014D41

Example of linear X-Y table

Figure 4
Linear X-Y table

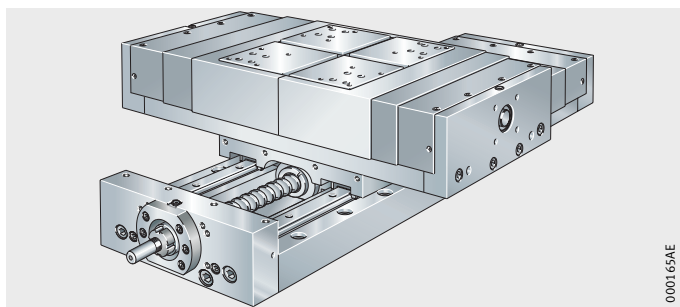

000165AE

Linear actuators with additional function

For special requirements, we offer a comprehensive product range of linear actuators with additional functions, *Figure 4*.

- Linear actuator with opposing carriages:
Two carriages moving in opposing directions are driven by means of a toothed belt.
- Telescopic actuator:
This linear actuator can be telescopically extended on both sides and the maximum stroke length is more than twice the total length.
- Linear actuator with integral gearbox:
The return unit contains an integral planetary gearbox, so the coupling and coupling housing can be omitted.

- ① Linear actuator with integral gearbox
- ② Linear actuator with opposing carriages
- ③ Telescopic actuator

Figure 4
Linear actuators with additional function

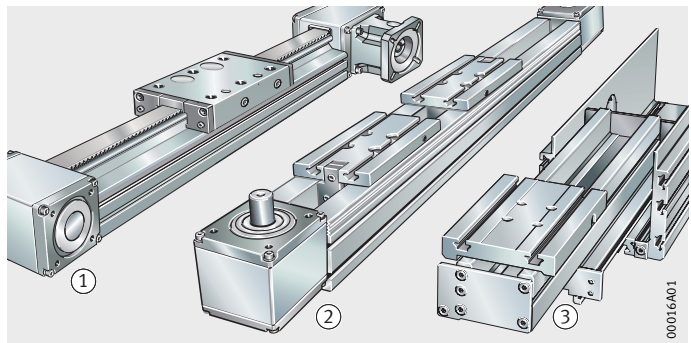

Accessories and drives and controls

A good complete solution comprises numerous components matched to each other. Driven linear units with the correct accessories and suitable drives and controls allow the most suitable solution, *Figure 5*.

- ① Fasteners
- ② Actuators
- ③ Couplings, coupling housings
- ④ Gearboxes, motors
- ⑤ Controllers

Figure 5
Accessories and drives and controls

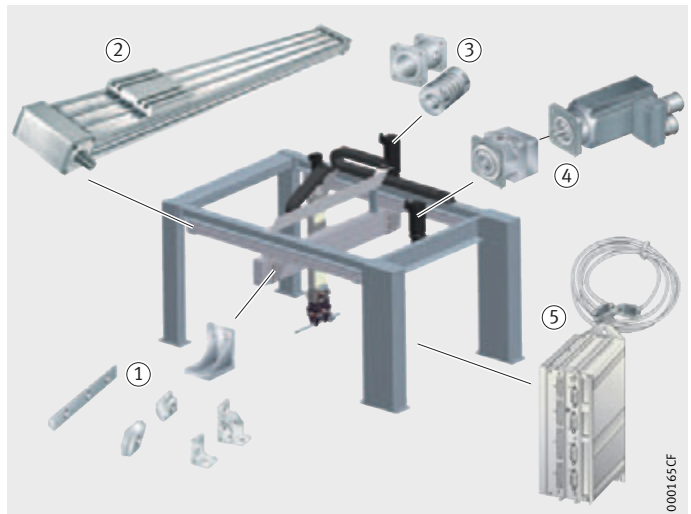

**Schaeffler Technologies
AG & Co. KG**

Linear Technology Division
Berliner Straße 134
66424 Homburg/Saar (Germany)
Internet www.ina.com
E-Mail info.linear@schaeffler.com

In Germany:

Phone 0180 5003872

Fax 0180 5003873

From other countries:

Phone +49 6841 701-0

Fax +49 6841 701-2625

Every care has been taken to ensure the correctness of the information contained in this publication but no liability can be accepted for any errors or omissions. We reserve the right to make technical changes.

© Schaeffler Technologies AG & Co. KG

Issued: 2012, April

This publication or parts thereof may not be reproduced without our permission.

PDB 8 GB-D